

NOTES

- 1- USE LATHE TO CLAMP ON THE OUTER PART OF THE PLANGE -» MACHINE INNER DIAMETER TO 95 MM H9
- 2 - CLAMP THE PART ON THE INSIDE -» MACHINE THE OUTSIDE FEATURES (132.5 h9, 3MM DEEP) AND MACHINE THE CHAMFER FOR WELDING

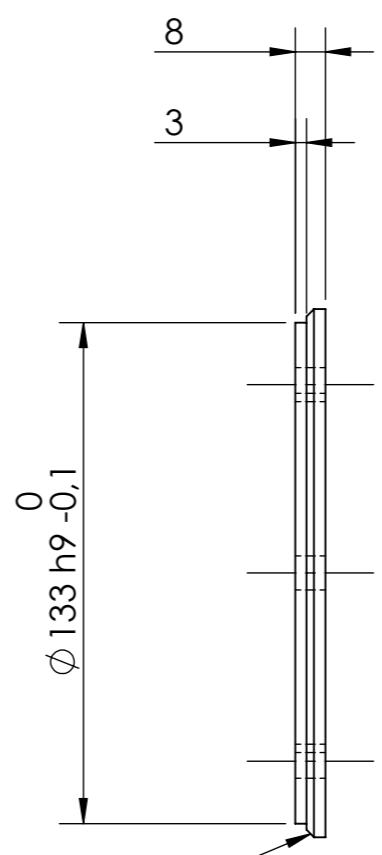

Welding chamfer 3x3 mm

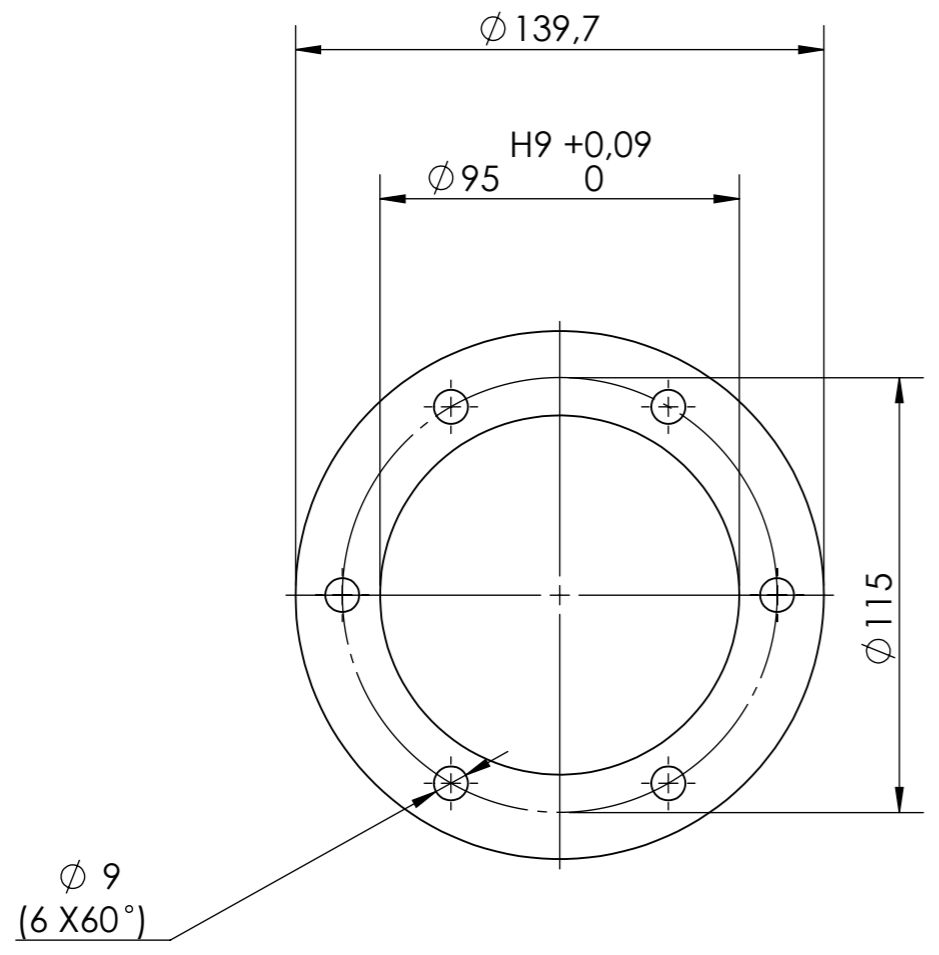

Weight		0.5 kg		Material		Mild Steel			
Machine		Extruder PRO		Description				Motor side flange	
Projection method:		First angle		Release date		Drawing no.		Rev.	
				07/01/20		EXTPRO-V1 1110.03		A	
General tolerances		ISO 2768-m		Doc. type	Part	Units unless specified	Sheet size	Scale	Sheet
						mm	A3	1:10	1 / 1