

8 7 6 5 4 3 2 1

F F

E E

D D

C C

B B

A A

NOTES:

- POINT WELD TO ASSEMBLE THE PARTS
- TIG WELD ALL AROUND

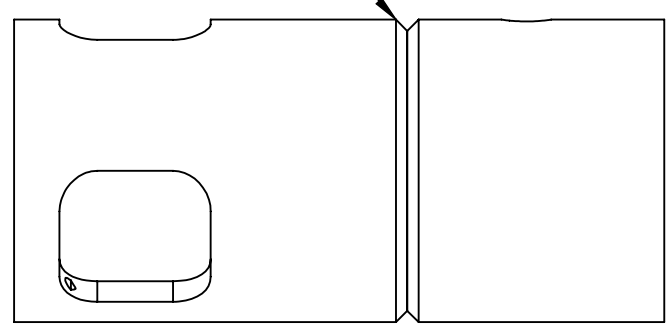

ALIGN THE BOLT PATTERNS

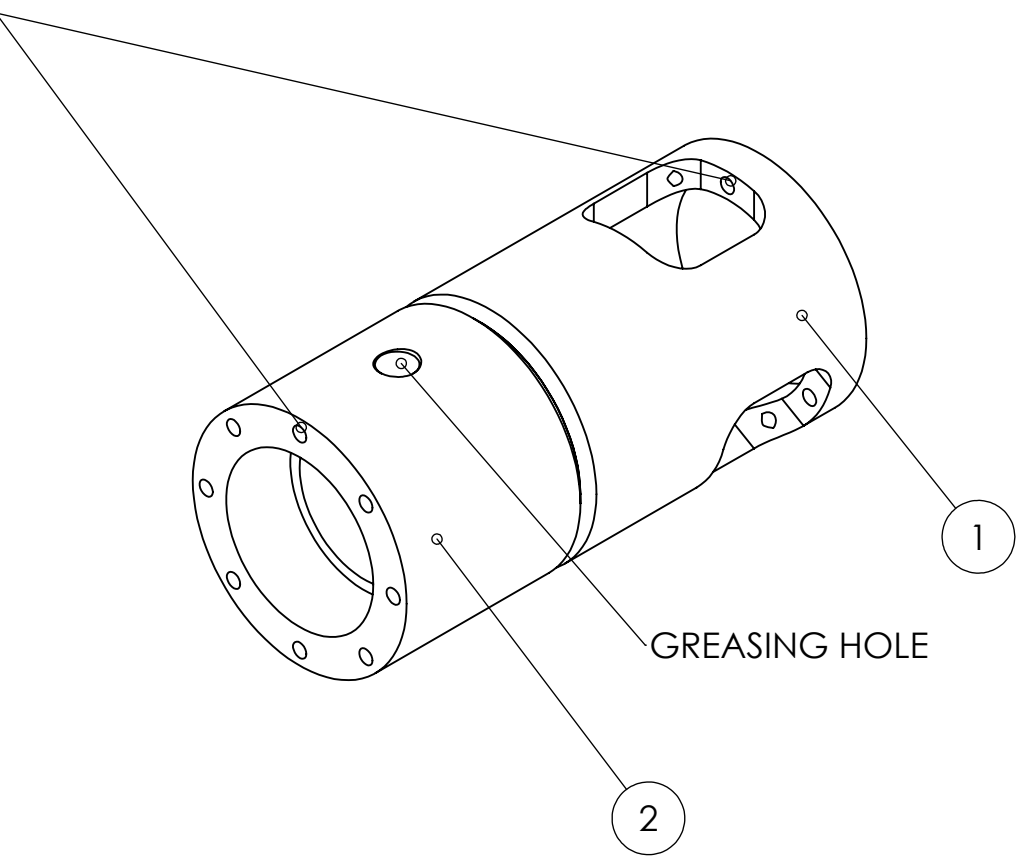

2	1	Bearing body	EXTPRO-V1 1121.02	Mild Steel
1	1	Transition Piece	EXTPRO-V1 1121.01	Mild Steel
ITEM NO.	QTY.	Part number	DRAWING NO.	MATERIAL

	Machine Extruder PRO		Description Bearing body		
	Projection method: First angle		Release date 07/11/20	Drawing no. EXTPRO-V1 1121.00	Rev. A
	General tolerances ISO 2768-m	Doc. type Assembly	Units unless specified mm	Sheet size A3	Scale 1:2

8 7 6 5 4 3 2 1