

- Base part is a laser cutted part.
- Material to be s235JR or stronger with good weldability
- Inner diameter and chamfer to be machined on a lathe has 2 mm extra material
- Holes to be drilled, position to be determined using either this drawing as a template, or spotting by a laser cutter

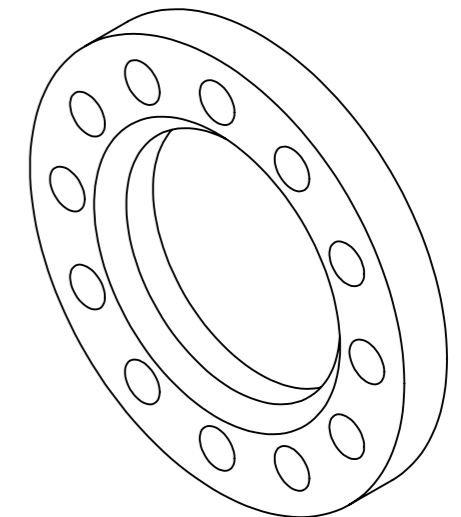

Section

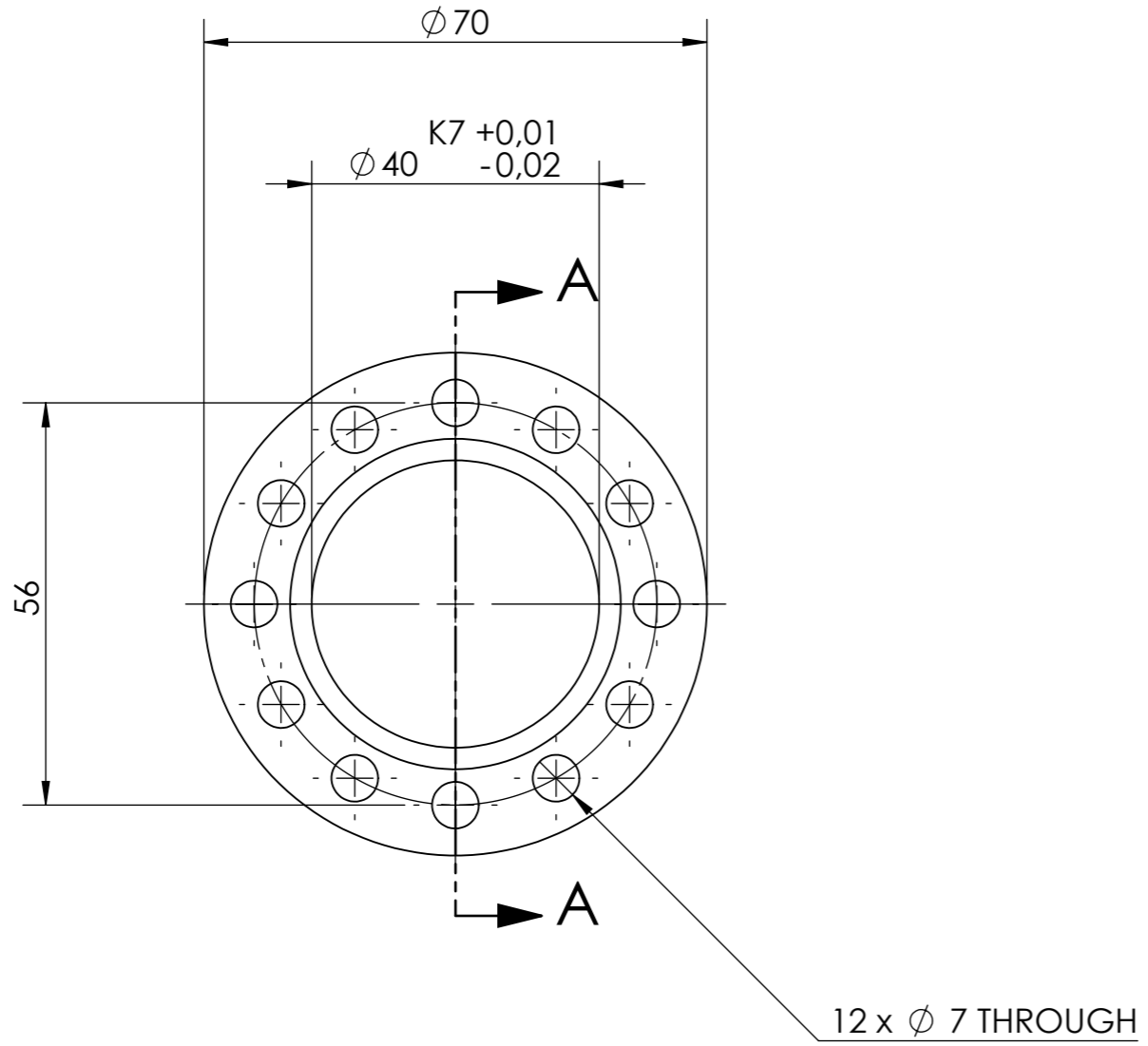
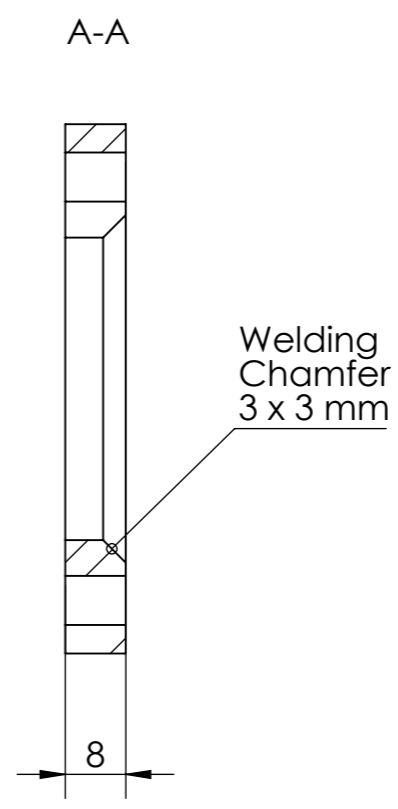

Stock material: Laser cutted plate, 8mm S235JR

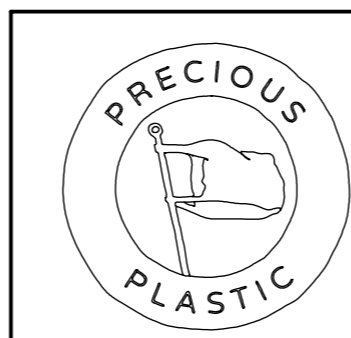

Weight		0.1 kg		Material		Mild Steel		
Machine		Extruder PRO		Description				Barrel flange
Projection method:		First angle		Release date		Drawing no.		Rev.
				07/01/20		EXTPRO-V1 1140.02		A
General tolerances		ISO 2768-m		Doc. type		Units unless specified		Sheet
				Part		mm		1 / 1
				A3		Scale		1:10